

User's Manual

Mini Sound Level Meter



Please read this user's manual thoroughly before using this unit and keep it properly for your future reference.

Contents

1. Safety	2
2. General Description	2
3. Specifications	3
4. Meter Description	5
5. LCD Display Description	7
6. Operation Instruction	8
7. Basic Operation	9
8. Operation Instruction	9
9. Operation Precautions	10
10. Accessories	10

1. Safety

Read the following safety information carefully before attempting to operate or service the meter.

Use the meter only as specified in this manual; otherwise, the protection provided by the meter may be impaired.

▲ Environment conditions:

- Altitude up to 2000 meters
- RH≤90% (Non-Condensation)
- Operating Temperature: -20~60°C

▲ Maintenance

- Repairs or servicing not covered in this manual should only be performed by qualified personnel.
- Wipe the unit with a dry soft cloth. Do not use abrasives or solvents on this instruments.

▲ Safety Symbol

CE Comply with EMC

2. General Description

This Sound Level Meter is designed to meet the measurement requirements of safety Engineers, Health, Industrial safety offices and sound quality control in various environments like factory, school, construction, etc.

- Comply with IEC61672-1 CLASS2 Standard
- Max/Min Record
- With one equivalent weighted sound pressure level A
- Screen lock function

3. Specifications

Applied standard	IEC61672-1 CLASS2
Accuracy	$\pm 1.4\text{dB}$
Frequency range	31.5Hz ~ 8KHz
Dynamic range	50dB
Measuring level range	30dB ~ 130dB
Frequency weighting	dBA
Microphone	1/2 inch electret condenser
Display	3 1/2 digits,
Resolution	0.1dB
Data update:	0.5 sec
Max Hold	MAX
Min Hold	MIN
Screen Lock	HOLD

Auto power off	Meter automatically shuts down after approx. 15 minutes of inactivity.
Power supply	One 9V battery, 006P or IEC 6F22 or NEDA 1604.
Battery life	at least 30 hours
Operating conditions	- 20°C ~ 60°C , 10%RH ~ 90%RH
Storage conditions	-20°C ~ 60°C , 10%RH ~ 75%RH
Dimension(L*W*H)	144* 55* 38mm
Weight:	90g
Accessories:	User's Manual, 9V battery and windscreen

4. Meter Description

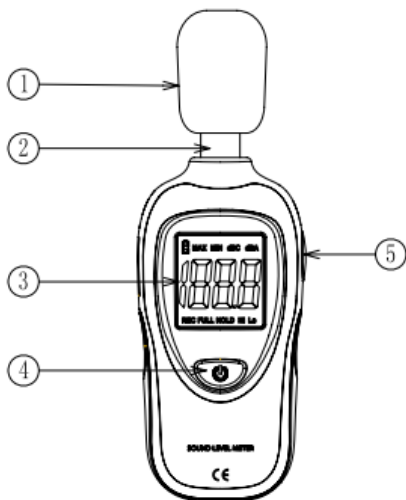

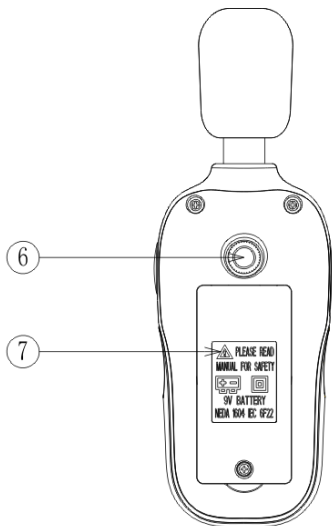

- (1) Windscreen microphone cover
- (2) Microphone
- (3) LCD display
- (4) Power ON/OFF button
- (5) MAX/MIN button
- (6) Tripod nut
- (7) Battery compartment

5. LCD Display Description





Icon	Function
LCD	3 1/2 digits
MAX	Max value hold
MIN	Min value hold
dBA	A frequency weighting (the noise that human ear can hear)
HOLD	Data hold
	Low battery indication

6. Operation Instruction

① Backlit & Power ON/OFF Function

Power ON: Turn the meter on by pressing button "" for 1 second until the LCD is lighted, then loose the button.

Power OFF: Turn the meter off by pressing and holding button "" for approx. 3 seconds until the LCD is switched off, then loose the button.

Backlit: After turning the meter on, momentarily press button "", the backlit will be on/off, it will automatically turn off after approx. 30 seconds of inactivity.

HOLD & MAX/MIN Function

HOLD: After turning the meter on, momentarily press "" button , "HOLD" icon will appear on the LCD, which indicates the data is freed. To release the held reading, press the button again.

MAX/MIN: Press and hold "" button for at least 3 seconds until "MAX" icon appears on the LCD to view the current MAX reading, press the button again, "MIN" icon will appears to view the current MIN

reading. To exit the MAX/MIN mode, press and hold the button "  " for 3 seconds.

7. Basic Operation

Open battery cover and install a 9-volt battery in the battery compartment.

Close the battery compartment.

When the low battery icon "  " appears, replace the meter's battery.

8. Operation Instruction

Power the meter on.

The meter will conduct measurement and select measurement range automatically. Measuring level range: 30dB ~ 130dB.

To freeze a displayed reading, momentarily press the "  " button, the "HOLD" icon will appear. To release the held reading, press the button again.

Press and hold button "  " for at least 3 seconds until "MAX" icon appears on the LCD to view the current MAX reading, press the button again, "MIN" icon will appears to view the current MIN reading. To

exit the MAX/MIN mode, press and hold the button "MAX/MIN" for 3 seconds to normal operation mode.

Hold the meter in hand or use the tripod to affix the meter in the desired location. The best measuring distance is 1~1.5m away from the microphone to the sound source.

9. Operation Precautions

- ① Do not store or operate the meter in areas of high temperature or humidity.
- ② Remove the battery when the meter is to be stored for long periods of time to avoid battery leakage.
- ③ Wind blowing across the microphone increases the noise measurement. Use the supplied windscreen to cover the microphone when appliance.
- ④ Keep microphone dry and avoid severe vibration.

10. Accessories

- ① User's manual
- ② Windscreen

